

Winter check

Document number: 150002072_00_en

Version: 19/06/2023

Bale wrapper

Easy Wrap (BW201, BW202)

Easy Wrap (BW301)

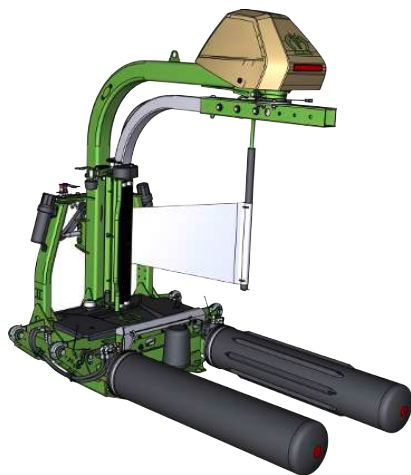

Table of contents

1	Foreword.....	3
2	Information on customer, KRONE service partner and machine.....	4
3	About this document.....	5
3.1	Validity.....	5
3.2	Re-ordering.....	5
3.3	Applicable documents.....	5
4	Personnel qualification of the technicians.....	6
5	Winter check list.....	7
5.1	Hydraulics.....	7
5.2	Frame.....	8
5.3	Electronics.....	9
5.4	Wrapping device.....	10
5.5	Field modifications.....	11
6	Certificate for winter check.....	12
7	Index.....	13

1 Foreword

Dear KRONE sales partner,

The name KRONE has been synonymous with agricultural technology for more than a decade. The perfect mixture of innovative power, customer proximity and expertise is the secret of the company's enduring success. The numerous innovative and unique features are testimony to the quality- and customer-oriented corporate philosophy.

As a recommendation / guideline for you, your KRONE Product Support Team has compiled this winter check.

To ensure the high quality of our products also beyond their sale, we recommend this winter check.

NOTE! This, however, does not serve to extend the warranty claim.

For you as a customer, this results in the following considerable benefits:

- Enhanced machine operational reliability
- Enhanced machine reliability during the season
- Longer machine lifetime
- Qualified post-season check according to KRONE quality standards by your local KRONE dealer
- Thorough post-season machine cleaning
- Higher resale value of your machine

Preparation:

- ✓ The machine has been cleaned completely by the customer.
- ✓ The machine is ready for operation.
- ✓ All customer and dealer data have been entered ([see Page 4](#)).

Implementation:

- ▶ Carry out all listed test steps for the respective component groups and check the result in the appurtenant column.
- ▶ In the "Comments" column, enter comments and additional information about the test steps carried out.
- ▶ Check that the field modifications are carried out as scheduled.
To do this, enter the serial number and then filter via KRONE Media ([KRONE Media](#)) for Service / Customer service information / Field modifications.

Completion:

- ▶ Dealer and customer mutually confirm the proper execution of the winter check. ([see Page 12](#))

With kind regards

Your KRONE Product Support Team



2 Information on customer, KRONE service partner and machine

Information on customer			
Company name:			
Surname, first name:			
Street address:			
Postal code / town:			
Telephone / cell phone:			
E-mail:			
<input type="radio"/> Farmer	<input type="radio"/> Contractor	<input type="radio"/> Machinery ring	

Information on KRONE service partner	
Company name:	
Surname, first name:	
Street address:	
Postal code / town:	
Telephone / cell phone:	
E-mail:	

Information on machine			
Machine type:		Vehicle identification number:	

3 About this document

3.1 Validity

This document is valid for:

BW201-10 (EasyWrap 150)

BW202-10 (EasyWrap 150)

BW301-20 (EasyWrap 165 T)

3.2 Re-ordering

You can request a replacement document if this document became completely or partly unusable, or if you need it in a different language. Please specify the document number shown on the cover page in your order. Alternatively, you can download the document online from KRONE MEDIA <https://media.mykrone.green>.

3.3 Applicable documents

To ensure that the machine is used safely and as intended, observe the following further applicable documents.

- Operating instructions of the respective machine
- Manual for service technicians "Repairs, maintenance and settings by technicians"

4 Personnel qualification of the technicians

If the work (assembly, conversion, modification, extension, repairs, retrofitting) is performed improperly on the machine, people may be seriously or fatally injured. To avoid accidents, everyone who performs work according to these instructions must meet the following minimum requirements:

- Qualified professional, with relevant training.
- Capable of assembling the (partially) disassembled machine according to the assembly instructions provided by the manufacturer.
- He is capable, e.g. by attending a training course, of extending, modifying or repairing the function of the machine according to the relevant instructions provided by the manufacturer.
- He has read the operating instructions and can implement the information in the operating instructions accordingly.
- Ability to perform the work safely according to these instructions.
- Understands the mode of operation of the work to be performed and the machine and is able to identify and avoid risk in carrying out the necessary work.
- Has read these instructions and is able to implement the information explained in these instructions accordingly.

5 Winter check list

INFO

For further information, refer to the operating instructions for the machine.

5.1 Hydraulics

	OK	Not OK	Rectified	Comment
Hydraulic hoses				
▶ Check for leak tightness				
▶ Check for damage				
Hydraulic connections				
▶ Check for leak tightness				
▶ Check for damage				
Control block				
▶ Check for leak tightness				
▶ Check function				
Pressure Filter				
▶ Check for leak tightness				
▶ Check filter change interval				Last change:
Cylinder bale pick-up				
▶ Check for leak tightness				
▶ Check function				
Cylinder bale turner (in "bale turner" version)				
▶ Check for leak tightness				
▶ Check function				
Cylinder holding and cutting device				
▶ Check for leak tightness				
▶ Check function				
Hydraulic motor and gearbox of the wrapping arm				
▶ Check for leak tightness				
▶ Check the function				
Hydraulic motor wrapping table				
▶ Check for leak tightness				
▶ Check the function				

5.2 Frame

	OK	Not OK	Rectified	Comment
Guards				
▶ Check for completeness				
▶ Check for firm seat				
▶ Check for damage				
▶ Check the function				
Hose cabinet				
▶ Check for completeness				
▶ Check for firm seat				
▶ Check for damage				
EasyWrap 150				
3-point hitch				
▶ Check for completeness				
▶ Check for firm seat				
▶ Check for wear				
▶ Check for damage				
EasyWrap 165 T				
Drawbar				
▶ Check for completeness				
▶ Check for firm seat				
▶ Check for wear				
▶ Check for damage				
EasyWrap 165 T				
Axle and wheel bearing				
▶ Check for wear				
▶ Check for damage				
▶ Check the settings				
EasyWrap 165 T				
Wheels				
▶ Check for wear				
▶ Check for damage				
▶ Check air pressure				
▶ Check the settings/play				

5.3 Electronics

	OK	Not OK	Rectified	Comment
Wiring and plug contacts				
▶ Check for damage				
Manual sensor test				
▶ Check the sensor settings, see operating instructions				
▶ Check the function				
Overall sensors				
▶ Check for damage				
Manual actuator test				
▶ Check the actuator function				
Lighting system				
▶ Check for damage				
▶ Check the function				
Test run of machine				
▶ Check the function				
Machine-specific settings				
▶ Check the settings, see operating instructions				

5.4 Wrapping device

	OK	Not OK	Rectified	Comment
Holding and cutting device				
▶ Check for completeness				
▶ Check for firm seat				
▶ Check for wear				
▶ Check for damage				
▶ Check the settings				
▶ Check the function				
Pre-stretch unit				
▶ Check for wear				
▶ Check for damage				
▶ Check the function				
Pre-stretch roll brake				
▶ Check for wear				
▶ Check for damage				
▶ Check the function				
Safety bracket				
▶ Check for completeness				
▶ Check for firm seat				
▶ Check for wear				
▶ Check for damage				
▶ Check the function				
Gearbox wrapping arm				
▶ Check for leak tightness				
▶ Check function				
▶ Check the play in the connection between the wrapping arm and the gearbox wrapping arm				
EasyWrap 165 T				
Wrapping table belt				
▶ Check for completeness				
▶ Check for leak tightness				
▶ Check function				

5.5 Field modifications

	OK	Modification not carried out (Document number)	Rectified
Scheduled field modifications			
▶ Check for completeness			

7 Index

A

About this document.....	5
Applicable documents	5

C

Certificate for winter check	12
Comments	12

E

Electronics.....	9
------------------	---

F

Field modifications.....	11
Foreword	3
Frame	8

H

Hydraulics.....	7
-----------------	---

I

Information on customer, KRONE service partner and machine	4
---	---

P

Personnel qualification of the technicians	6
--	---

R

Re-ordering	5
-------------------	---

V

Validity.....	5
---------------	---

W

Winter check list	7
Wrapping device.....	10



THE POWER OF GREEN



Maschinenfabrik

Bernard Krone GmbH & Co. KG

✉ Heinrich-Krone-Straße 10
D-48480 Spelle

✉ Postfach 11 63
D-48478 Spelle

☎ +49 (0) 59 77 / 935-0

📠 +49 (0) 59 77 / 935-339

🌐 www.landmaschinen.krone.de

